

Igo 28 A

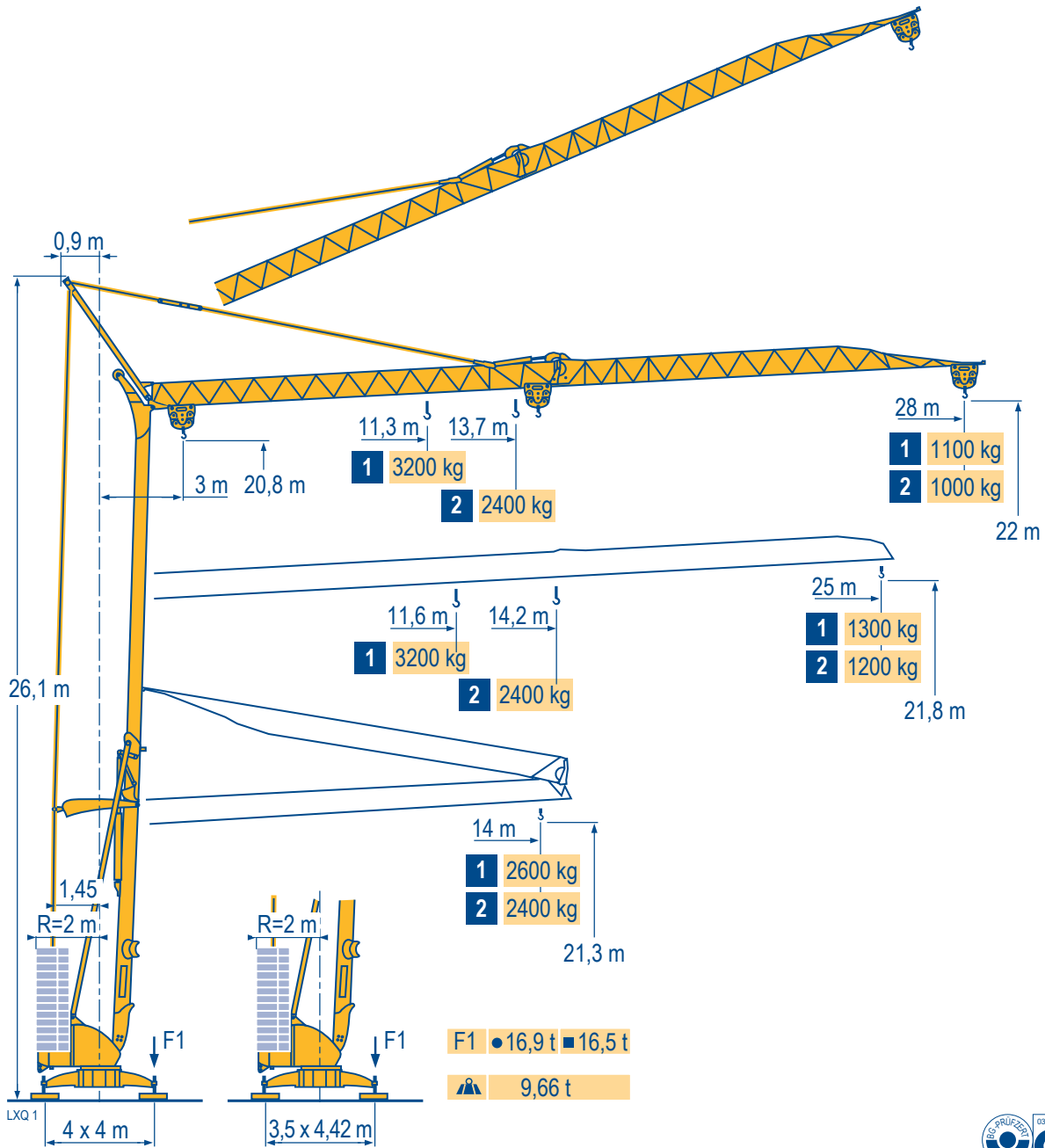

Courbes de charges
Lastkurven
Load diagrams
Curvas de cargas
Curve di carico
Curva de cargas



Curve di carico
Curva de cargas

LXQ 1

28 m	3	▶	11,9	12	13	14	m	11,3	12	13	14	15	16	17	18	19	20	20,6	21	22	23	24	25	26	27	28	m				
			3200	3165	2855	2600	kg	3200	2950	2665	2425	2220	2045	1895	1765	1645	1540	-	1450	1365	1290	1220	1160	1100	1050	1000	kg				
																						1600	1560	1475	1400	1325	1265	1205	1150	1100	kg

25 m	3	▶	11,9	12	13	14	m	11,6	12	13	14	15	16	17	18	19	20	21	22	23	24	25	m				
			3200	3165	2855	2600	kg	3200	3045	2750	2500	2290	2115	1960	1820	1700	1595	1500	1415	1335	1265	1200	kg				
																						1600	1520	1440	1365	1300	kg

2 2400 kg

28 m	3	▶	14	m	13,7	14	15	16	17	18	19	20	21	22	23	24	25	26	27	28	m
			2400	kg	2400	2340	2150	1985	1845	1720	1610	1510	1425	1345	1275	1210	1150	1095	1045	1000	kg
25 m	3	▶	14	m	14,2	15	16	17	18	19	20	21	22	23	24	25	m				
			2400	kg	2400	2240	2070	1920	1790	1675	1575	1485	1405	1330	1260	1200	kg				

Fleche relevée
Ausleger in Steilstellung
Luffing jib
Flecha izada
Braccio impennato
Lança inclinada

LXQ 1

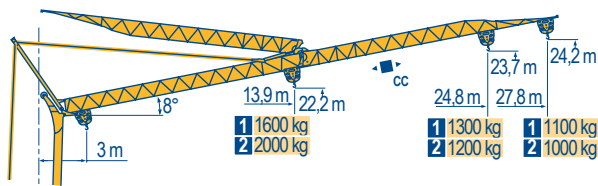

28 m	3	▶	19,3	20	20,4	21	22	23	24	25	26	27	27,8	m
			1600	1530	-	1435	1355	1280	1210	1150	1090	1040	1000	kg
			1600	1545	1465	1385	1315	1250	1195	1140	1100	kg		
25 m	3	▶	19,8	20	20,9	21	22	23	24	24,8	m			
			1600	1580	-	1485	1400	1320	1250	1200	kg			
			1600	1590	1500	1425	1355	1300	kg					
28 m	3	▶	15,8	17	19	21	22	23	24	25	26	27	27,8	m
			2000	1830	1595	1410	1335	1265	1200	1140	1085	1035	1000	kg
25 m	3	▶	16,3	17	19	21	22	23	24	24,8	m			
			2000	1900	1660	1470	1390	1315	1250	1200	kg			

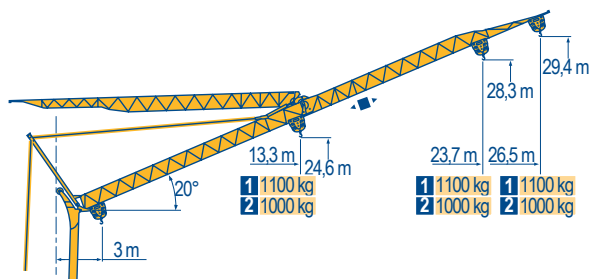

28 m	3	▶	26,5	m									
			1000	kg									
			1100	kg									
25 m	3	▶	23,7	m									
			1000	kg									
			1100	kg									
28 m	3	▶	26,5	m									
			1000	kg									
25 m	3	▶	23,7	m									
			1000	kg									

Igo 28 A

POTAIN



F
Chariot distributeur
Chariot distributeur et courbes de charges



Reactions en service
Reactions hors service
A vide sans lest (ni train de transport) avec fleche et hauteur maximum.



D
Verfahrbare Laufkatze

Verfahrbare Laufkatze und Lastkurven
Reaktionskräfte in Betrieb
Reaktionskräfte außer Betrieb
Ohne Last, Ballast (und Transportachse), mit Maximalausleger und Maximalhöhe.

GB
Traversing trolley

Traversing trolley and load diagrams
Reactions in service
Reactions out of service
Without load, ballast (or transport axes), with maximum jib and maximum height.

E
Carro distribuidor

Carro distribuidor y curvas de cargas
Reacciones en servicio
Reacciones fuera de servicio
Sin carga, sin lastre, (ni tren de transporte), flecha y altura máxima.

I
Carrellino distributore

Carrellino distributore e curve di carico
Reazioni in servizio
Reazioni fuori servizio
A vuoto, senza zavorra (ne assali di trasporto) con braccio massimo e altezza massima.

P
Carro distribuidor

Carro distribuidor e curva de cargas
Reações em serviço
Reações fora de serviço
Sem carga (nem trem de transporte)- sem lastro com lança e altura máximas.

Mécanismes
Antriebe
Mechanisms
Meccanismi
Mecanismos

LXQ 2

												ch - PS hp	kW	
▲ ▼	15 LVF 10 Optima	m/min	3,6	18	37	49	66						15	11
		kg	1600	1600	1600	1100	500							
		m/min	3,6	18	37	54	66	1,8	9	19	27	33		
		kg	1600	1600	1600	1000	500	3200	3200	3200	2000	1000		
◀ ▶	3 DVF5	m/min	19 - 41									3	2,2	
⦿	RVF+31	tr/min U/min rpm	0 → 0,8									3	2,2	
▲ ▼	10 LVF 12 Optima	m/min	2	10	17	34	40						10	7,5
		kg	2400	2400	2400	1000	500							
◀ ▶	2 DVF5	m/min	15 - 38 (0 → 1000 kg)					15 - 30 (1000 → 2400 kg)					2	1,5
⦿	RVF2-30	tr/min U/min rpm	0 → 0,8									2	1,5	
		CEI 38	IEC 38		kVA									
		400 V (+6% -10%) 50 Hz					15 LVF 10 : 20 kVA 10 LVF 12 : 14 kVA							

15 LVF 10
Optima

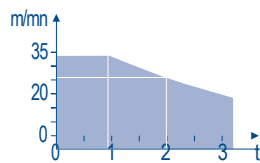

10 LVF 12
Optima

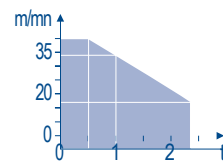

Montage
Montage
Erection
Montaje
Montaggio
Montagem

LXQ 1

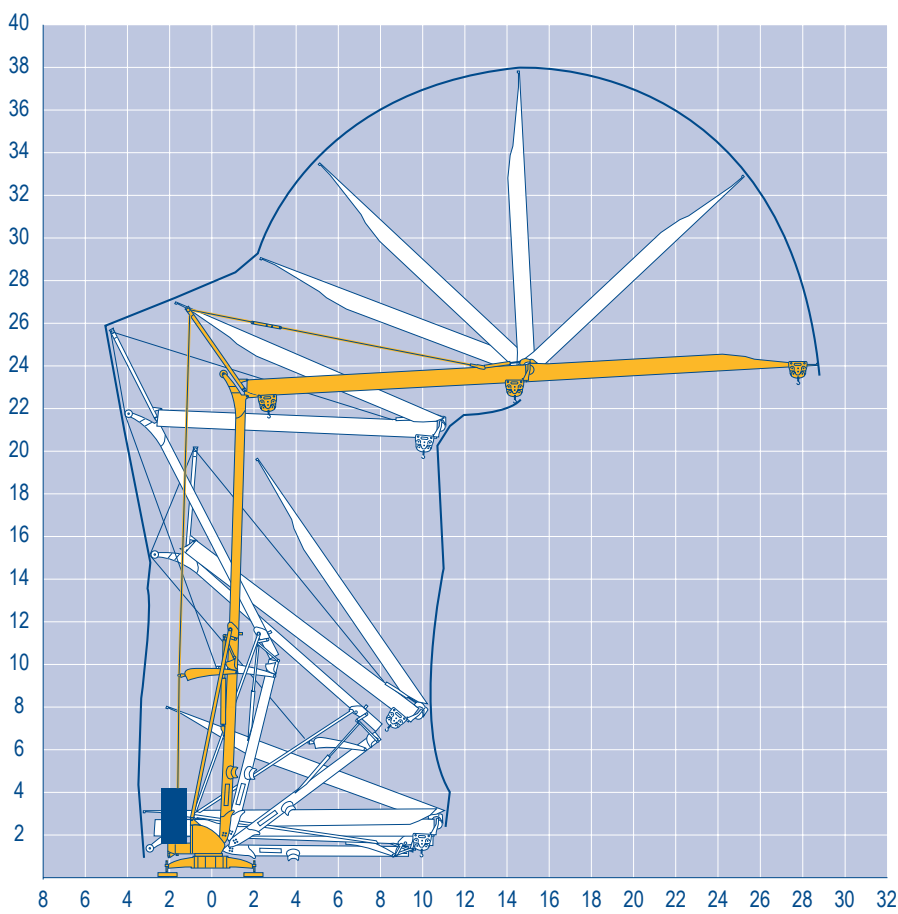

Igo 28 A

POTAIN

F



Levage
Distribution
Orientation

D

Heben
Katzfahren
Schwenken

GB

Hoisting
Trolleying
Slewing

E

Elevación
Distribución
Orientación

I

Sollevamento
Distribuzione
Rotazione

P

Elevação
Distribuição
Rotação

Transport
Transport
Transport
Transporte
Trasporto
Transporte

		L (m)	B (m)	C (m)	D (m)	H (m)
DS61/S120	○					
DS61/S125	DS61/S120	15,9	2,45	4	6,81	3,05/3,2
DJ80/S120	○					
DJ80/S125	DJ80/S120	15,9	2,45	4	6,81	3,1
DJ100/S120	DJ80/S125	15,9	2,45	4	6,81	3,1
DJ100/S125	DJ100/S120	16,33	2,45	4	6,81	3,1/3,23
DJ105/S125	DJ105/S125	16,33	2,45	4	6,81	3,1/3,23
DJ126M/S125	DJ126M/S125	16,35	2,45	4	6,81	3,2
DJ126M/S215M	DJ126M/S215M	17,14	3,24	4,07	6,74	3,55
DJ126M/S125						
DJ126M/S215M						

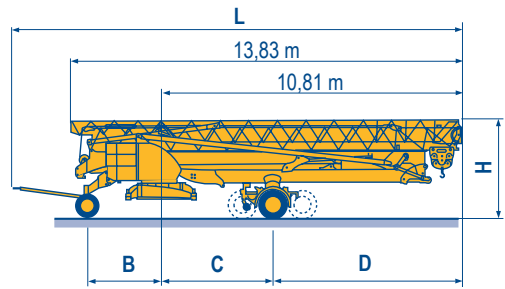

LXQ 2

		C (m)	D (m)
SL122/J215M			
SL121/J135	SL122/J215M	4,07	6,74
SL121/S215M	SL121/J135	4	6,81
	SL121/S215M	4,07	6,74

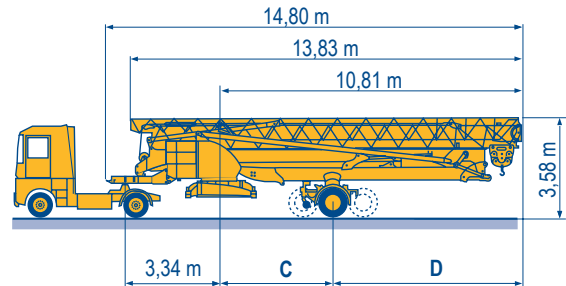

	F	D	GB	E	I	P
○	Chantier	Baustelle	Site	Obra	Cantiere	Estaleiro



Document commercial non contractuel. Pour toute information technique se référer à la notice correspondante.

Unverbindliches Vertriebsdokument. Für technische Informationen, siehe die entsprechenden Anweisungen.

This commercial document is not legally binding. For any technical information, please refer to the corresponding instructions.

Documento comercial non contractuel. Para cualquier información técnica, ver la noticia correspondiente.

Documento commerciale non vincolante, per tutte le informazioni tecniche fare riferimento al catalogo istruzioni.

Documento comercial não contratual. Para qualquer informação técnica complementar consultar as respectivas instruções.



18, rue de Charbonnières - B.R.173
69132 ECULLY Cedex - France

Tél. : +33 (0) 4 72 18 20 20
Fax. : +33 (0) 4 72 18 20 00
www.manitowoccrane.com



Americas
Tel : +1 888 479 7278
Tel : +1 717 593 2000

Europe - Middle East - Africa
Tel : +33 (0) 4 72 81 50 00
Tel : +44 (0) 191 522 2000

Asia - Pacific
Tel : +65 6264 1188
Fax : +65 6862 4142

www.manitowoccrane.com

Igo 28 A
Réf. 2003 48 LXQ 3

Copyright.Reproduction interdite © POTAIN 2003

Réalisation Secdoc